

- NL - x2
- NP - x2
- DD - x8
- DKD - x1
- DK - x5
- BRK - x4
- DR - x2
- SCH - x3
- LDS - x4
- LKS - x2
- ST - x20-32

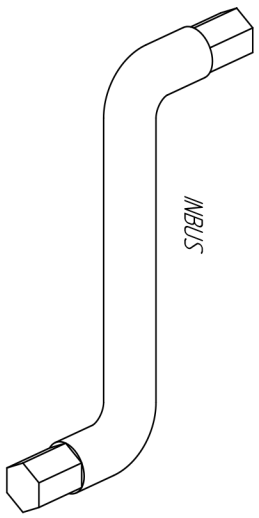

- S110 - x16
- S80 - x16
- S50 - x14
- S40 - x4
- W30 - x28
- K10 - x34
- G - x4
- INBUS - x1

Quantity of holes for mattress bar and number of ST part.

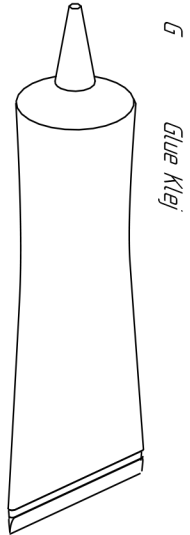
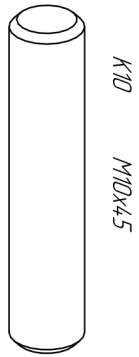
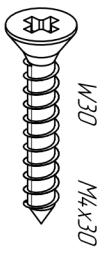
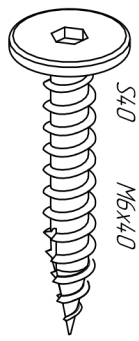
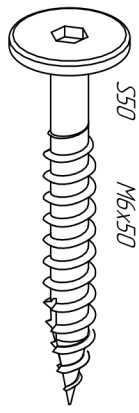
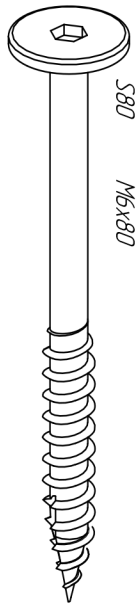
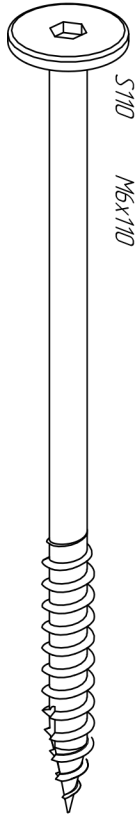
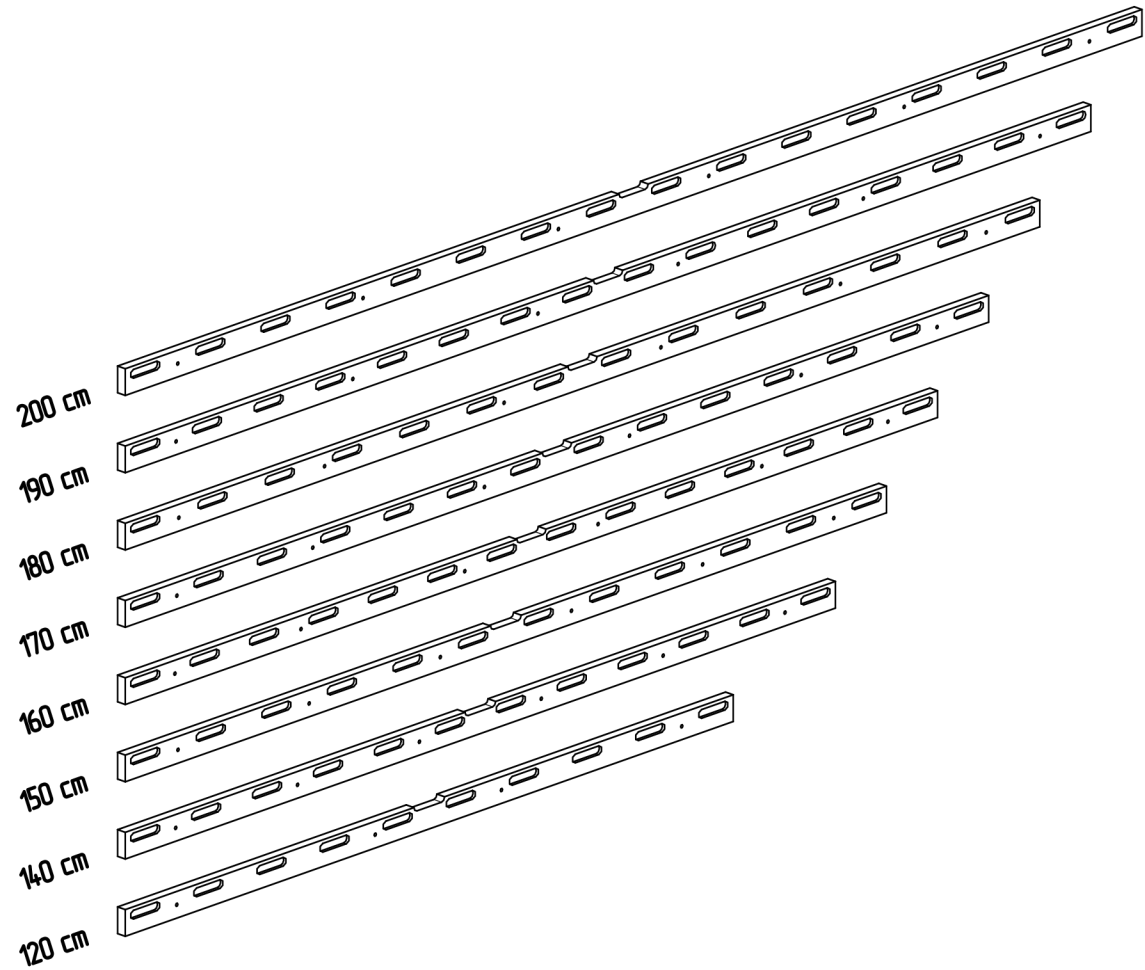

<i>Length</i>	<i>QT</i>
<i>200 cm</i>	<i>16</i>
<i>190 cm</i>	<i>16</i>
<i>180 cm</i>	<i>14</i>
<i>170 cm</i>	<i>14</i>
<i>160 cm</i>	<i>14</i>
<i>150 cm</i>	<i>12</i>
<i>140 cm</i>	<i>12</i>
<i>120 cm</i>	<i>10</i>

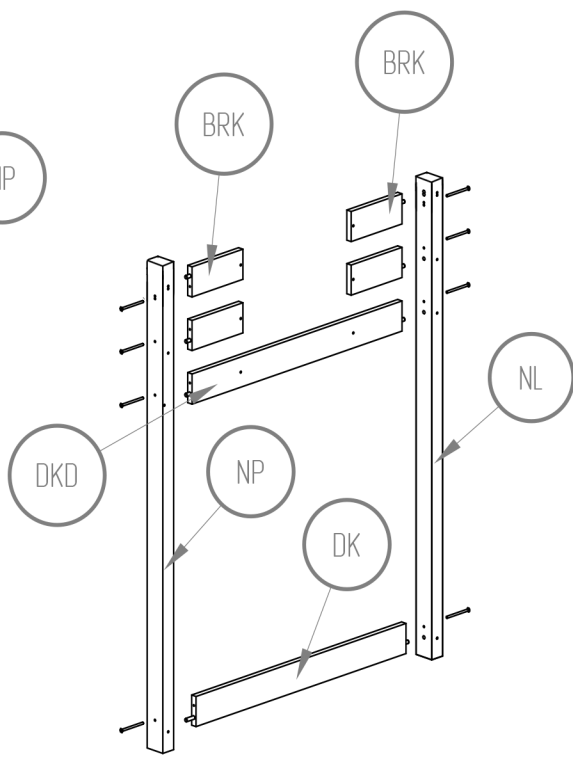
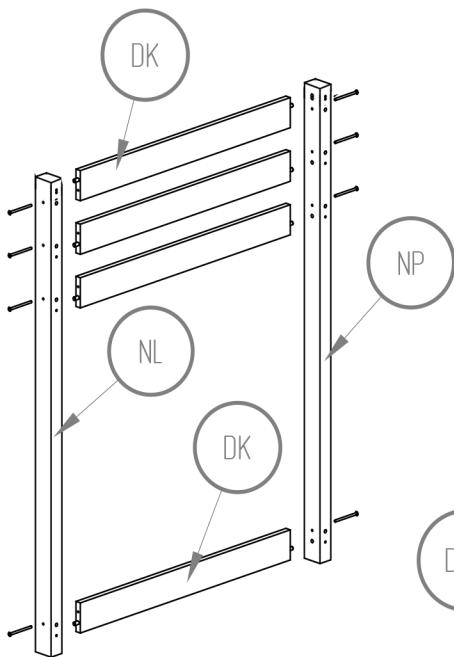
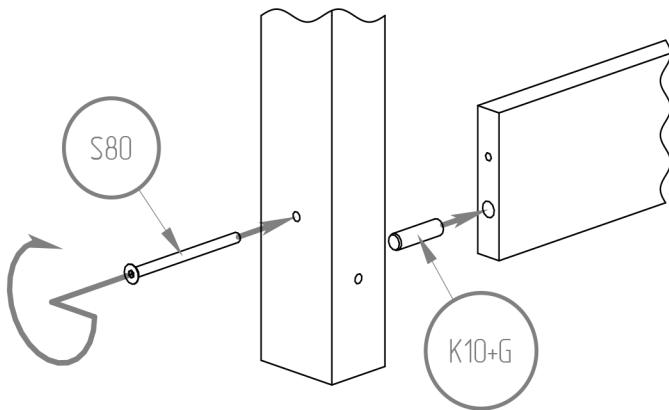
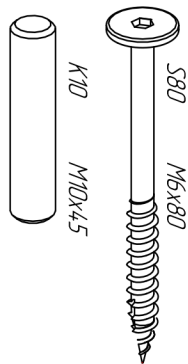

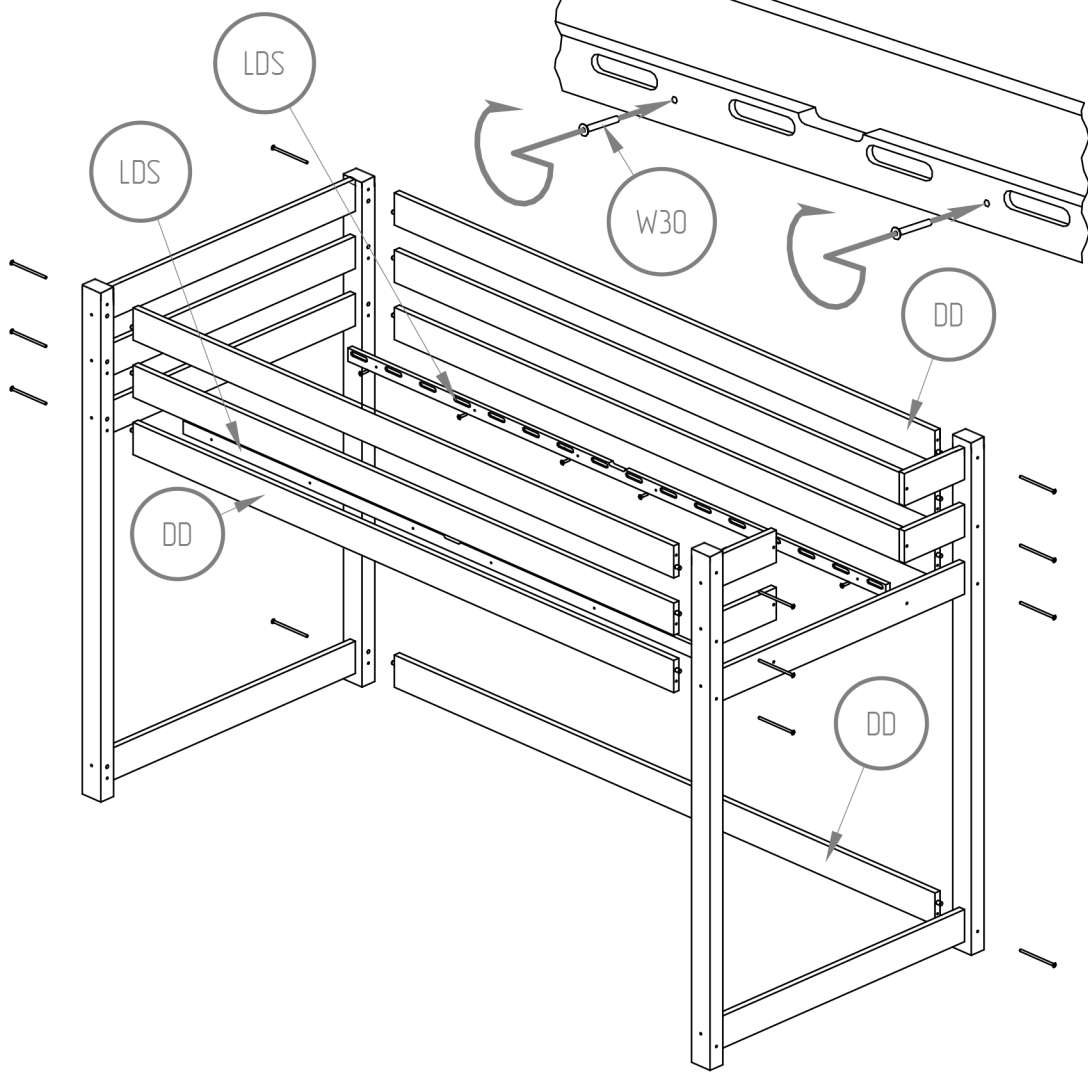
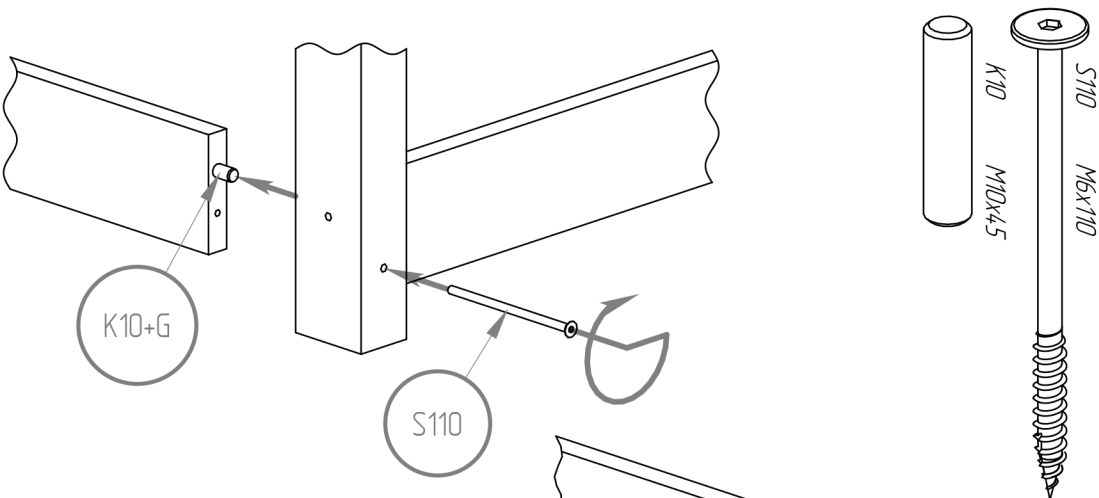

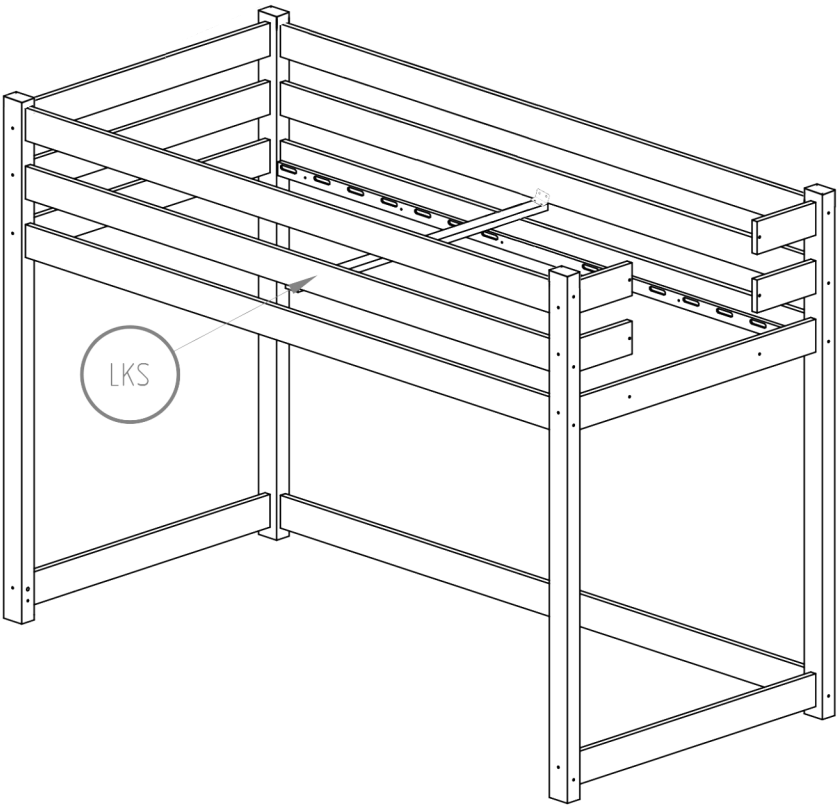
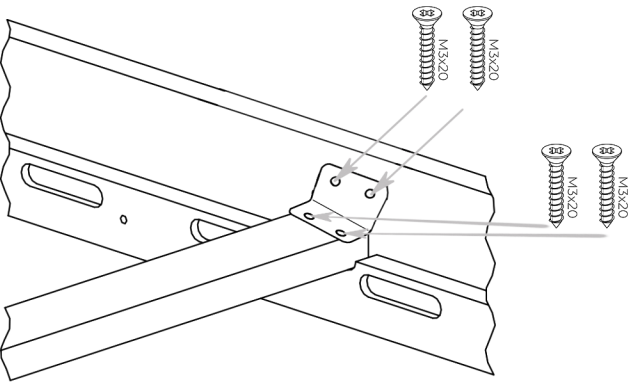
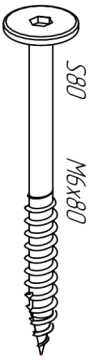

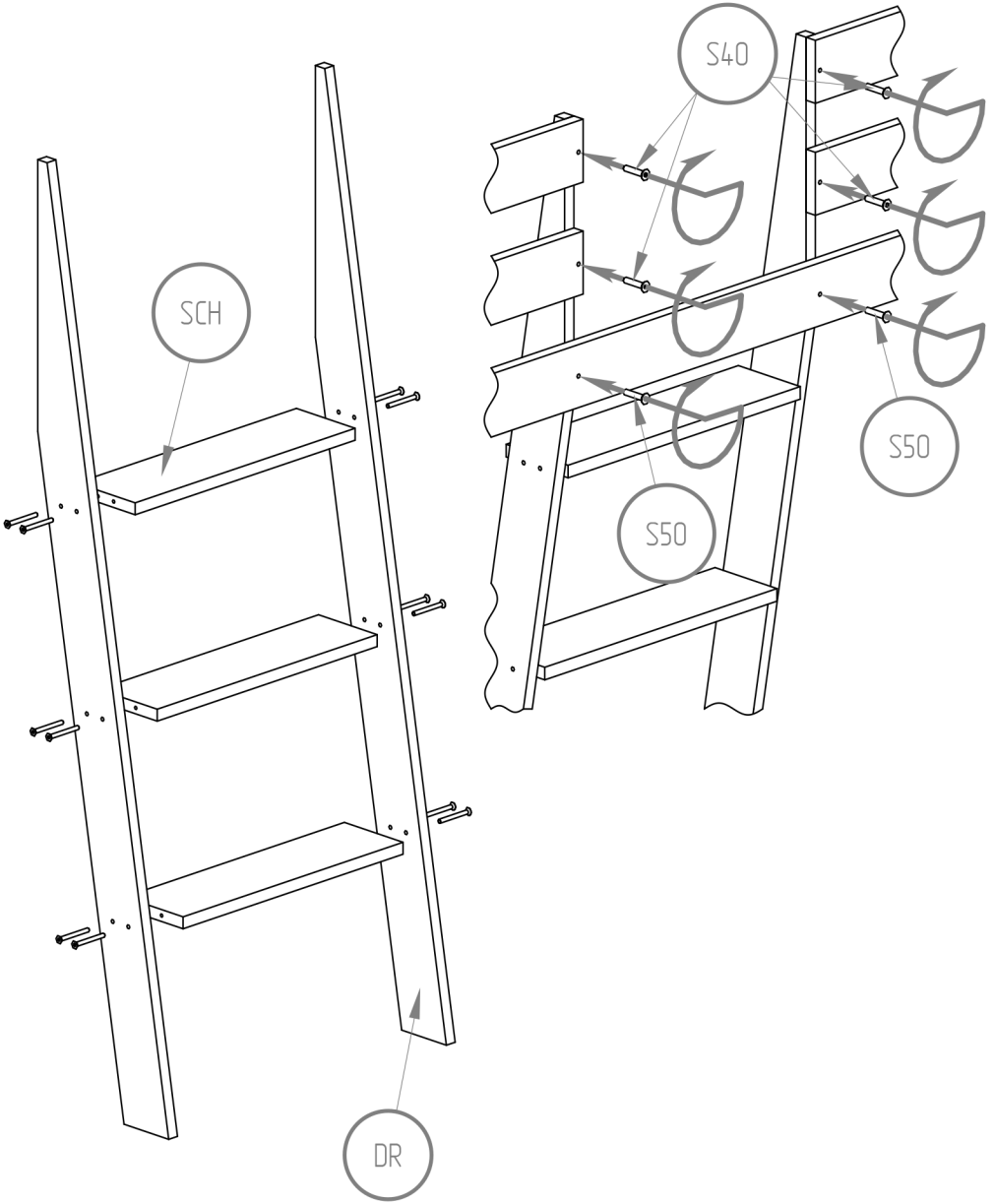
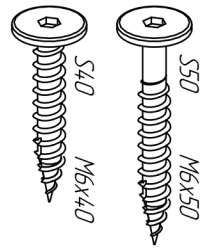
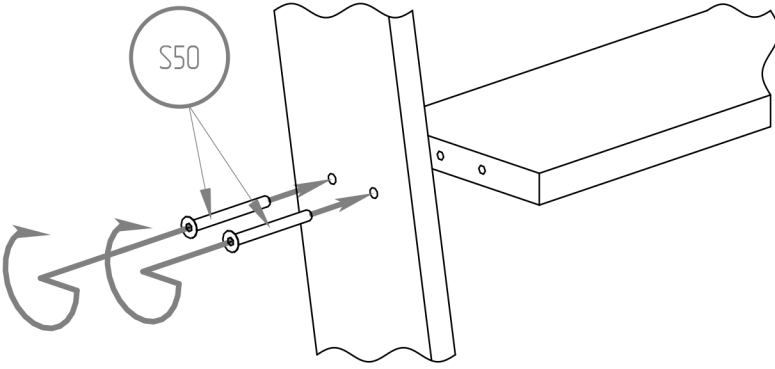

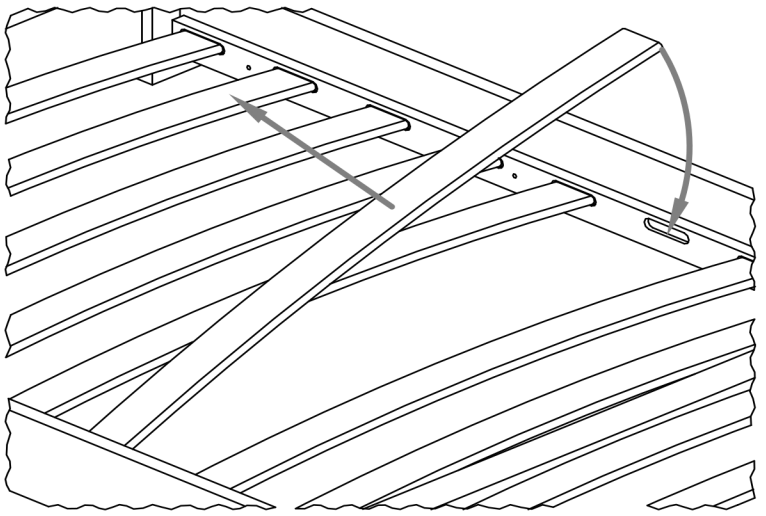

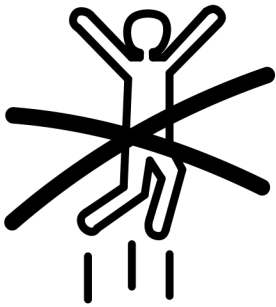

NIE SKAKAĆ

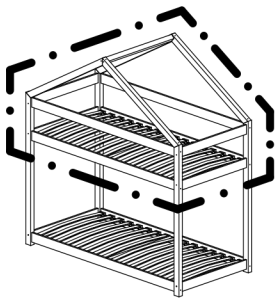

*Górne tóżko dla dzieci
powyżej 6 roku życia.*

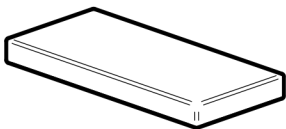

Wysokość materaca:

min. 8 cm

max. 12 cm



UWAGA !

*ABY ZAPOBIEC POWAZNYM URAZOM I USZKODZENIOM
CIAŁA NALEŻY:*

- *Nigdy nie pozwalać dzieciom poniżej 6 roku życia przebywać na górnej pryczy.*
- *Używać tylko materacy o grubości 8-12 cm.*
- *Używać poręczy po obu stronach górnej pryczy.*
- *Nie skakać na lub pod tóżkiem (tóżkach).*
- *Zakazywać przebywania więcej niż jednej osoby na górnym tóżku.*
- *Używać drabiny, aby wejść i wyjść z górnej pryczy.*
- *Nie wieszać się na elementach konstrukcyjnych.*

Części drewniane i plastikowe należy czyścić za pomocą suchej szmatki oraz zwykłych, łagodnych środków do pielęgnacji i czyszczenia surowego drewna.

Zaprojektowano i wykonano zgodnie z normą:

PN-EN 747-1+A1:2015-08

NIEBEZPIECZEŃSTWO ZAGROŻENIA – Nigdy nie podłączaj ani nie zawieszaj przedmiotów do jakiegokolwiek części tóżka piętrowego, do której nie są przeznaczone.



NO JUMPING

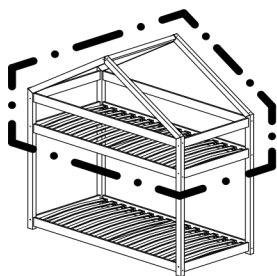

*Upper bed for
children 6+ years old*

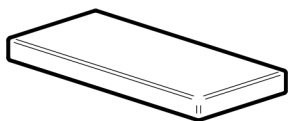

Mattress height:

min. 8 cm

max. 12 cm



WARNING !

*TO HELP PREVENT SERIOUS OR FATAL INJURIES FROM
ENTRAPMENT OF FALLS:*

- Never allow a child under 6 years on upper bunk.*
- Use only mattress with thickness is 8-12 cm height.*
- Use guardrails on both sides of upper bunk.*
- Prohibit horseplay on or under bed(s).*
- Prohibit more than one person on upper bunk.*
- Use ladder for entering and leaving upper bunk.*
- Do not hang on construction components.*

*Wooden and plastic parts should be cleaned with a
dry cloth and ordinary, mild care and cleaning of raw
wood.*

*Designed and made according to the standard:
PN-EN 747-1+A1:2015-08*

*STRANGULATION HAZARD - Never attach or hang
items to any part of the bunk bed that are not
designed for use with the bed.*